

# Hawk 3 Temperature Meter/Controller



- All parameters set from easy to understand front panel access
- One, two or four 5-amp relays optional
- 7-segment 4 digit red LED
- Five user-selectable brightness levels
- Activated set point indicators on display
- Min/Max and password lockout
- NEMA 4X rated front panel
- RS485 digital communications output available by special order
- 4-20mA or 0-10 DCV analog retransmission optional
- 1/8 DIN, shallow depth case, 3.24"
- Din Rail Adapter available (page C1)

## Ordering Information



Selection Description Selection Description

Selection	Description	Selection	Description
H340	<b>Basic Unit</b> 4 digit, Red LED	0	<b>Output</b> None
		1	4-20 DCmA
		2	0-10 DCV
1	<b>Power Supply</b> 120 ACV		
3	9-36 DCV	0	<b>5A Relays</b> None
4	85-250 ACV	1	One
		2	Two
91	<b>Function/Range</b> J Thermocouple	4	Four
92	K Thermocouple		
93	RTD, PT100 3-wire	0	<b>Excitation</b> None
94	E Thermocouple	1	12 DCV - 100mA max current
95	T Thermocouple	2	24 DCV - 100mA max current

## Specifications

### DISPLAY

Type	7-segment, red LED
Quantity	4
Height	0.56" (14.2mm)
Brightness	5 settings, user programmable
Overrange indication	Display flashes "EEEE" indicating Maximum Value Exceeded
Underrange indication	Display flashes "-EEEE" indicating Minimum Value Exceeded

Sensor Break Excitation	Display reads "EEEE" 100mA Max Current
-------------------------	---

### POWER REQUIREMENTS

AC	85 to 250 VAC/120VAC @ 10VA
DC	9 to 36 DCV @ 10VA

ACCURACY @ 25°C as % of rdg	Accuracy	Temperature Range
Sensor Type		
RTD Pt 100	0.2% ± 2 counts	-200°C to +200°C
J	0.2% ± 2 counts	-100°C to +760°C
K	0.2% ± 2 counts	-200°C to +1250°C
E	0.2% ± 2 counts	-100°C to +800°C
T	0.2% ± 2 counts	-200°C to +400°C

### ENVIRONMENTAL

Operating Temperature	0 to 50°C
Storage Temperature	-10 to +60°C
Relative Humidity	<80%
Ambient Temp	25°C
Temperature Drift	100 ppm/°C ± 0.05 dgt/°C
Warmup time	10 minutes

### NOISE REJECTION

NMRR	60 dB @ 50-60 Hz
CMRR	100 dB @ 50-60 Hz

### A TO D CONVERSION

Technique	Successive approximation with oversampling
Sample Rate	10 conversions per second
Display Rate	User programmable from 1/minute - 8/second

### MECHANICAL

Bezel	3.92" X 2.0" X 0.52" (99.8mm x 51.8mm x 13.2mm)
Depth	3.24" (82.3mm) behind panel
Panel cutout	3.62" x 1.77" (92 mm x 45 mm) 1/8 DIN
Weight	10oz (283.5g)
Cover	NEMA 4X Rated front panel



more >>



# Hawk 3 Installation Instructions

## Installation and Panel Cutout - H335, H340, H345

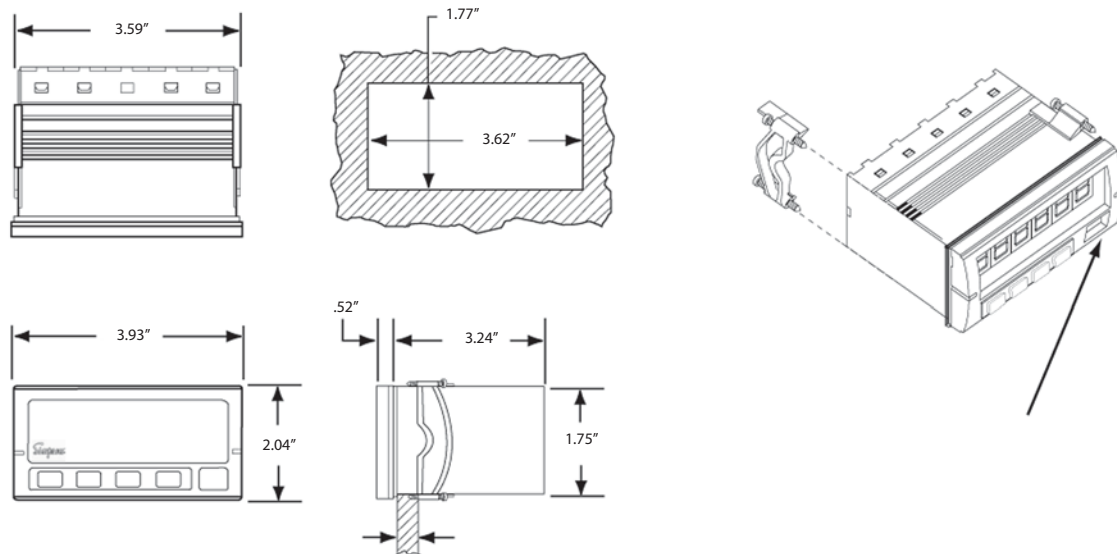

### Mounting Requirements

The Hawk 3 Advanced Digital Controller 1/8 DIN meters require a panel cutout of 1.77" (45mm) high and 3.62" (92 mm) wide). To install the Hawk 3 meter into the panel cutout, remove the clips from the side of the meter. Slide the meter through the panel cutout, then slide the mounting clips back on the meter. Press evenly to ensure a proper fit. Tighten screws.

### Engineering Label Placement

To replace the engineering unit label, place the tip of a ballpoint pen into the small hole at the base of the engineering label in the bezel. Slide the label up until it pops out. Grasp and remove. Slide the new label half the distance in, then use the ballpoint pen to slide it into place.

## Inputs

### DC Voltage

Range	Resolution 4.5	Resolution 3.5	Input Impedance	Overload
200mV	10µV	.1 mV	1 MΩ	10DCV
2 V	.1mV	1 mV	1 MΩ	100DCV
20 V	1mV	10 mV	2 MΩ	100DCV
200 V	10 mV	.1 V	2 MΩ	300DCV
600 V	.1 V	1V	2 MΩ	1K DCV

### DC Current

Range	Resolution 4.5	Resolution 3.5	Input Impedance	Overload
200µA	10 nA	.1 mA	1KΩ	11mA DC
2 mA	.1µA	1 mA	100Ω	35mA DC
20 mA	1µA	10 mA	10Ω	111mA DC
200mA	10 µV	.1 mA	1Ω	353 mA DC
2 A	.1 mA	1 mA	.013Ω	7A DC
5 A	.1 mA	1 mA	.013Ω	7A DC

### AC Current

Range	Resolution 4.5	Resolution 3.5	Input Impedance	Overload
200µA	10 nA	.1 mA	1KΩ	11mA AC
2 mA	.1µA	1 mA	100Ω	35mA AC
20 mA	1µA	10 mA	10Ω	111mA AC
200mA	10 µV	.1 mA	1Ω	353mA AC
2 A	.1 mA	1 mA	.013Ω	7A AC
5 A	.1 mA	1 mA	.013Ω	7A AC

### AC Voltage

Range	Resolution 4.5	Resolution 3.5	Input Impedance	Overload
200mV	10µV	.1 mV	200KΩ	10DCV
2 V	.1mV	1 mV	200KΩ	100DCV
20 V	1mV	10 mV	2 MΩ	300DCV
200 V	10 mV	.1 V	2 MΩ	300DCV
600 V	.1 V	1V	2 MΩ	1K DCV

### Resistance

Range	Resolution 4.5	Resolution 3.5	Input Impedance	Overload
200mΩ	10mΩ	.1Ω	1.2KΩ	± 5DCV
2Ω	.1Ω	1Ω	12KΩ	± 5DCV
20Ω	1Ω	10Ω	121Ω	± 5DCV
200Ω	10Ω	.1Ω	1.2MΩ	± 5DCV