

Model JKW-5A SUPERBUTE™

Outdoor Current Transformer
15,000 V, 5A to 1,200 A, 50/60 Hz, 110 kV BIL

Application

Designed for outdoor service; suitable for operating meters, relays, and control devices. Features 0.15 accuracy from 5% of nameplate amps through rating factor within burden capability. Available in a variety of ratio as outlined in the unit selection table below, with additional designs available upon request. Rated Station Class with higher burden and extra creep distance.

Features

- Weight: 60 lbs (unit), 75 lbs (shipping)
- Dimensions: : 15.69" (h) x 10.88" (w) x 12.75" (d)
- Creep Distance: 24" [609.6 mm]
- Strike Distance: 9" [229 mm]
- Insulation: HY-BUTE 60™ Butyl Rubber
- Insulation Class: 110 kV BIL, Outdoor
- Design Standard: IEEE C57.13
- Measurement Canada Approval: AE-2017

Reference Drawings & Accessories

Accuracy Curve(s) at 60 Hz

- 5 A to 600 A & 1,200 A - 9932600131
- 800 A - 9932600150

Excitation Curve(s)

- 5 A to 600 A & 1,200 A 9932600133
- 800 A 9932600151

Accessories

- "L" Mounting Brackets 8944634002
- Channel Bracket 5466227001
- Suspension Hooks 8944630001
- Secondary Conduit Box 9689897001



Unit Selection

JKW-5A

Current Ratio	Meter Class	RF ¹	Mechanical Limit, Amps	1-Sec Thermal Limit, Amps	Catalog Number
5:5	0.15S B0.5	1.5	625	425	755x053101
10:5	0.15S B0.5	1.5	1,250	930	755X053102
15:5	0.15S B0.5	1.5	1,875	1,470	755X053103
20:5	0.15S B0.5	1.5	2,500	1,860	755X053104
25:5	0.15S B0.5	1.5	3,125	2,300	755X053105
30:5	0.15S B0.5	1.5	3,750	2,460	755X053106
40:5	0.15S B0.5	1.5	5,000	3,720	755X053107
50:5	0.15S B0.5	1.5	6,250	4,600	755X053108
75:5	0.15S B0.5	1.5	9,375	6,375	755X053109
100:5	0.15S B0.5	1.5	12,500	8,600	755X053110
150:5	0.15S B0.5	1.5	18,750	12,750	755X053111
200:5	0.15S B0.5	1.5	25,000	17,200	755X053112
300:5	0.15S B0.5	1.5	37,500	25,800	755X053114
400:5	0.15S B0.5	1.5	50,000	36,000	755x053115
600:5	0.15S B0.5	1.5	75,000	51,600	755x053117
800:5	0.15S B0.5	1.2	80,000	63,200	755x053118
1,000:5	0.15S B0.5	1.0	100,000	82,000	755x053119
1,200:5	0.15S B0.5	1.0	100,000	82,000	755x053120

1. "RF" is defined as Continuous Thermal Rating Factor at 30 °C, ambient

Selection Guide

Product Class	5 KV	8.7 KV	15 KV	25 KV	35 KV	46 KV	69 KV
Station Class	JKW-3A	JKW-4A	JKW-5A	JKW-150A	JKW-200A	JKW-250A	JKW-350A
				JKW-150ER	JKW-200ER	JKW-250ER	JKW-350ER
BIL	60 kV BIL	75 kV BIL	110 kV BIL	150 kV BIL	200 kV BIL	250 kV BIL	350 kV BIL
Accuracy, Rating Factor*	0.15SB0.5, RF 1.5	0.15SB0.5, RF 1.5	0.15SB0.5, RF 1.5	0.15SB0.5, RF 1.5	0.15SB0.5, RF 1.5	0.15SB1.8, RF 1.5	0.15SB1.8, RF 1.5
Creep Distance	12.5" Creep	12.5" Creep	24" Creep	44.1" Creep	56.6" Creep	71.0" Creep	86.6" Creep
Net Weight	40 lbs	40 lbs	60 lbs	323 lbs	348 lbs	543 lbs	593 lbs
Distribution Class	JKW-6A						
BIL	150 kV BIL						
Accuracy, Rating Factor*	0.15SB0.5, RF 1.5						
Creep Distance	24" Creep						
Net Weight	80 lbs						

Dimensions, Mounting & Wiring Diagram

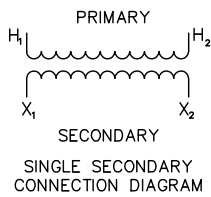
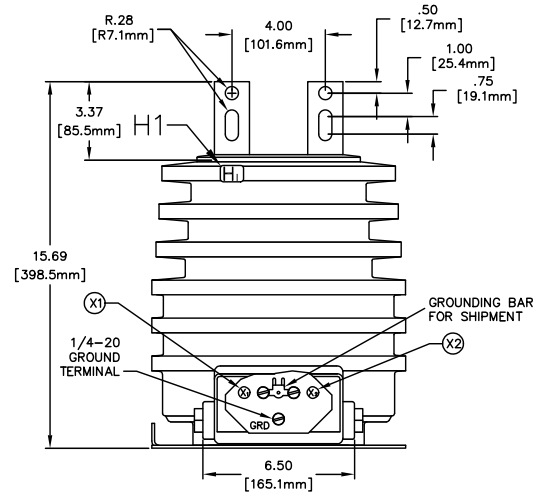
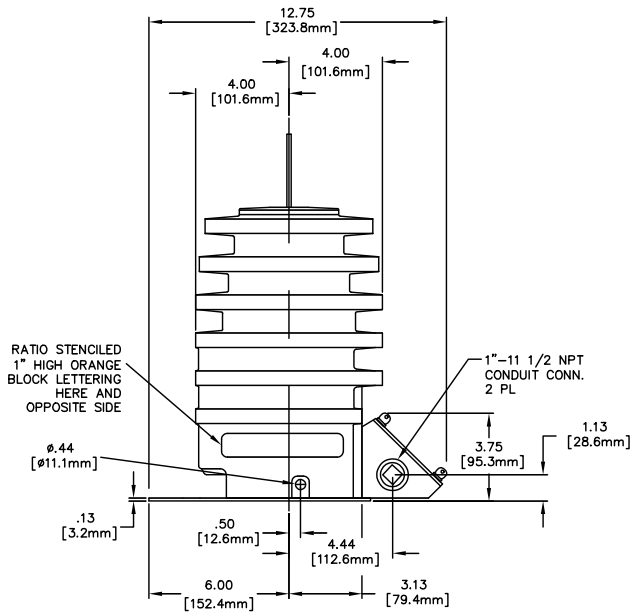

AMPS	H1/H2 TERMINAL DIMS	
	A	B
5 TO 150	1.5 (1.38MM)	.19 (4.8MM)
200 TO 400	2 (50.8MM)	.25 (6.4MM)
500 TO 1200	2 (50.8MM)	.38 (9.5mm)

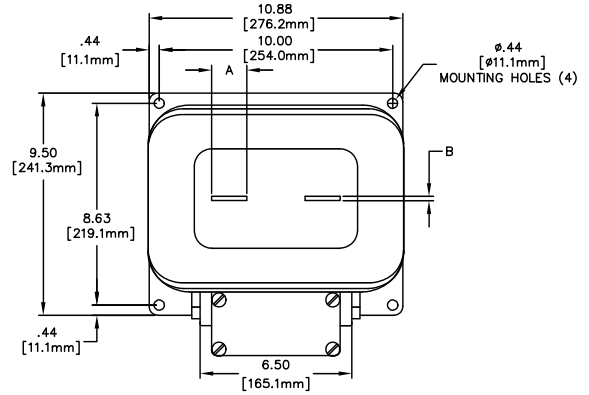

	Current Transformer	Type	Ratio	General Electric Co. Somersworth, NH USA
	Bil 110 kV NSV 15 kV 50-60 Hz	JKW-5A	50:5	
	RF = 1.5 @ 30°C Amb		Amp	
	Acc Cl @ 60 Hz 0.15 E-0.04 thru B-0.5, 0.3 B-1.8, T200			
	[0.15S B-0.1 thru B-0.5]			
Caution: Read GEH-230	AE-XXXX	Cat. 755X053108	Mfd. 0111 Ser. 1234567	

Construction Details

Insulation

The transformer design is constructed using GE's premium HY-BUTE 60 molded butyl rubber insulation for the transformer body. First introduced in 1955, GE's unique formulation is non-arc tracking and resistant to heat, chemicals, ozone and ultraviolet. This tough, resilient insulating material has proven to be superior in handling mechanical, electrical and environmental extremes, when compared against other insulation designs such as porcelain, urethane or epoxy.

Core & Coil

The core is made of high-permeability, formed, silicon steel strip. The steel is characterized by having highly directional properties, that is, low core losses and high permeability in the direction of rolling. Full advantage is taken of this property of the steel by the shape and construction of the core. The core has a dispersed-gap construction with interleaved laminations. This type of core provides a construction that will not shift to cause any change in the transformer characteristics. After being assembled into the coils, the core is securely clamped and permanently fastened to the base plate by a heavy steel strap which encircles the core and is welded to the base.

Windings

The primary winding consists of two coils connected in series. Each coil surrounds one leg of the core. This design reduces leakage losses, thus improving the accuracy of the transformer. It also provides a higher mechanical strength than a single coil construction. The secondary winding consists of two coils connected in parallel. Each coil is located inside the corresponding primary coil and surrounds one leg of the core.

Primary Terminals

The primary terminals are flat copper bars, each with one bolt hole and a slot, which facilitates connections to various size cable lugs. The terminal surfaces are tin-plated to reduce contact resistance, and to allow connection to either copper or aluminum conductors.

Secondary Terminals & Conduit Box

The secondary terminals are in a compartment molded in the side of the transformer. The compartment has a molded phenolic cover held by four brass, nickel-plated, captive thumbscrews, which engage a metal insert molded in the rubber. The thumbscrews are drilled to accommodate a seal wire. The compartment also has two openings for 1 inch conduit connection. The secondary terminals are the threaded type, each with cup washer, lock washer and nut. A manually operated, secondary short-circuiting switch is located between the secondary terminal studs.

Testing

Rigorous GE test requirements go beyond ANSI/IEEE routine requirements in order to ensure long term reliability. Test reports are saved electronically and can be e-mailed in various formats upon request.

Ground Terminal

A ground terminal is provided in the secondary compartment for making an optional connection to one of the secondary terminals. The 1/4-20 round-head ground terminal is welded in the baseplate bracket, and is furnished with a nut, cup washer, flat washer, and lock washer.

Polarity

The primary and secondary polarity markers are molded in the insulation. They are thus permanent and integral parts of the transformer and cannot readily be obliterated. The polarity is subtractive.

Baseplate and Mounting

The base is made of stainless-steel. A stainless-steel grounding lug is welded to the baseplate and provides a hole for attaching the grounding connector. Mounting holes or slots are located in each corner of the baseplate. Mounting hardware is supplied with the transformer. The transformer can be mounted with the primary terminals in any position—up, down, or horizontal. It can be bolted directly to a crossarm attached by "U" bolts or suspension hooks, or mounted on double crossarms, using channel brackets. Refer to the Accessories Listing on the transformer data sheet for Catalog Numbers.

Nameplate

The nameplate is made of stainless-steel and located on the base of the transformer. Information is per IEEE designation, laser-engraved for easy-to-read form. Custom barcoding available upon request.

Maintenance

These transformers require no maintenance other than an occasional cleaning if installed in an area where air contamination is severe.

GEGridSolutions.com

Grid-AIS-L4-ITL_Model_JKW_5A-1476-2017_07-EN. © Copyright 2017. General Electric Company and Instrument Transformers LLC reserve the right to change specifications of described products at any time without notice and without obligation to notify any person of such changes.

Worldwide Contact Center

Web: www.GEGridSolutions.com/contact

Phone: +44 (0) 1785 250 070

USA and Canada: +1 (0) 800 547 8629

Europe, Middle East and Africa: +34 (0) 94 485 88 00

