



MV Indoor Voltage Transformer

**Models PTG5-1-110
PTG5-2-110**

CERTIFICATIONS:



E475096



237637

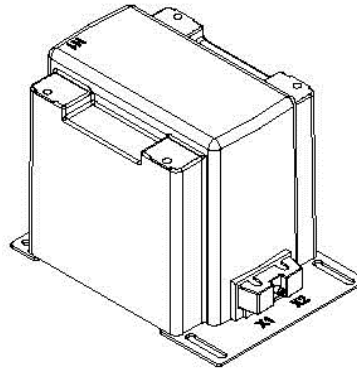

ACCURACY CLASS:

0.3 WXYZ, 1.2ZZ at 100% rated voltage with 120V based ANSI burden; 0.3 WXY, 1.2Z at 58% rated voltage with 69.3V based ANSI burden

FREQUENCY:

60 Hz.

MAXIMUM SYSTEM VOLTAGE:

15.5kV, BIL 110kV full wave

THERMAL RATING:

1500 VA at 30°C. amb.

1000 VA at 55°C. amb.

APPROXIMATE WEIGHT:

85 lbs., unfused

- Primary terminals that are unfused are ¼ - 20 brass screws with one flat washer and lockwasher, unless otherwise specified.
- Primary terminals that are fused are ¼ - 20 brass screws with one flat washer, lockwasher and two nuts.
- Secondary terminals are No. 10-32 brass screws with one flat washer and lockwasher.
- The core and coil assembly is vacuum encapsulated in polyurethane resin.
- Thermal burden rating is for 120 volt secondaries
- Plated steel mounting base.
- Fuses have 1.63" Dia Caps and 11.50" clip centers.
- Switchgear style is similar to fused style. No fuse or fuse clip is provided, but inserts for fuse clips are supplied.
- A test cord is provided with each unit.

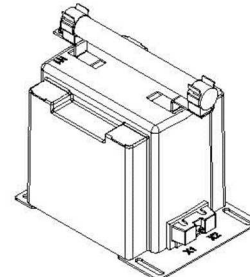
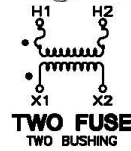
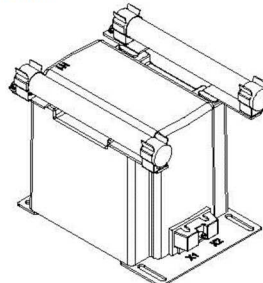
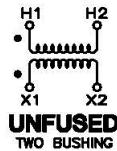
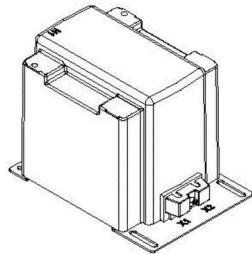

GROUP	ONE BUSHING (b)			RFR FR (c)	CATALOG NUMBERS		
					FUSES	FUSE CLIPS ONLY	SWITCHGEAR STYLE
4A	7200	60:1	120	65	PTG5-1-110-722F	PTG5-1-110-722C	PTG5-1-110-722S
4A	8400	70:1	120	65	PTG5-1-110-842F	PTG5-1-110-842C	PTG5-1-110-842S
4B	11000	100:1	110-50Hz	65	PTG5-1-110-113F	PTG5-1-110-113C	PTG5-1-110-113S
4B	12000	100:1	120	65	PTG5-1-110-123F	PTG5-1-110-123C	PTG5-1-110-123S
4B	13200	110:1	120	65	PTG5-1-110-1322F	PTG5-1-110-1322C	PTG5-1-110-1322S
4B	14400	120:1	120	65	PTG5-1-110-1442F	PTG5-1-110-1442C	PTG5-1-110-1442S

GROUP	TWO BUSHING (a)				CATALOG NUMBERS			
	PRIMARY VOLTAGE	RATIO	SECONDARY VOLTAGE	UNFUSED	FUSES	FUSE CLIPS ONLY	SWITCHGEAR STYLE	
1	7200	60:1	120	PTG5-2-110-722	PTG5-2-110-722FF	PTG5-2-110-722CC	PTG5-2-110-722SS	
1	8400	70:1	120	PTG5-2-110-842	PTG5-2-110-842FF	PTG5-2-110-842CC	PTG5-2-110-842SS	
2	11000	100:1	110-50Hz	PTG5-2-110-113	PTG5-2-110-113FF	PTG5-2-110-113CC	PTG5-2-110-113SS	
2	12000	100:1	120	PTG5-2-110-123	PTG5-2-110-123FF	PTG5-2-110-123CC	PTG5-2-110-123SS	
2	13200	110:1	120	PTG5-2-110-1322	PTG5-2-110-1322FF	PTG5-2-110-1322CC	PTG5-2-110-1322SS	
2	14400	120:1	120	PTG5-2-110-1442	PTG5-2-110-1442FF	PTG5-2-110-1442CC	PTG5-2-110-1442SS	

Products are manufactured in a plant whose quality management system is certified / registered as being in conformity with ISO 9001

- (a) Two fuse transformers should not be used for Y connections. It is preferred practice to connect one lead from each voltage transformer directly to the neutral terminal using a fuse in the line side of the primary only. By using this connection, a transformer can never be made "live" from the line side by reason of a blown fuse in the neutral side. For continuous operation, the transformer primary voltage should not exceed 100% of rated value.
- (b) Voltage transformers connected line-to-ground cannot be considered to be grounding transformers and must not be operated with the secondaries in closed delta because excessive currents may flow in the delta.
- (c) Possibility of ferroresonance should be considered.

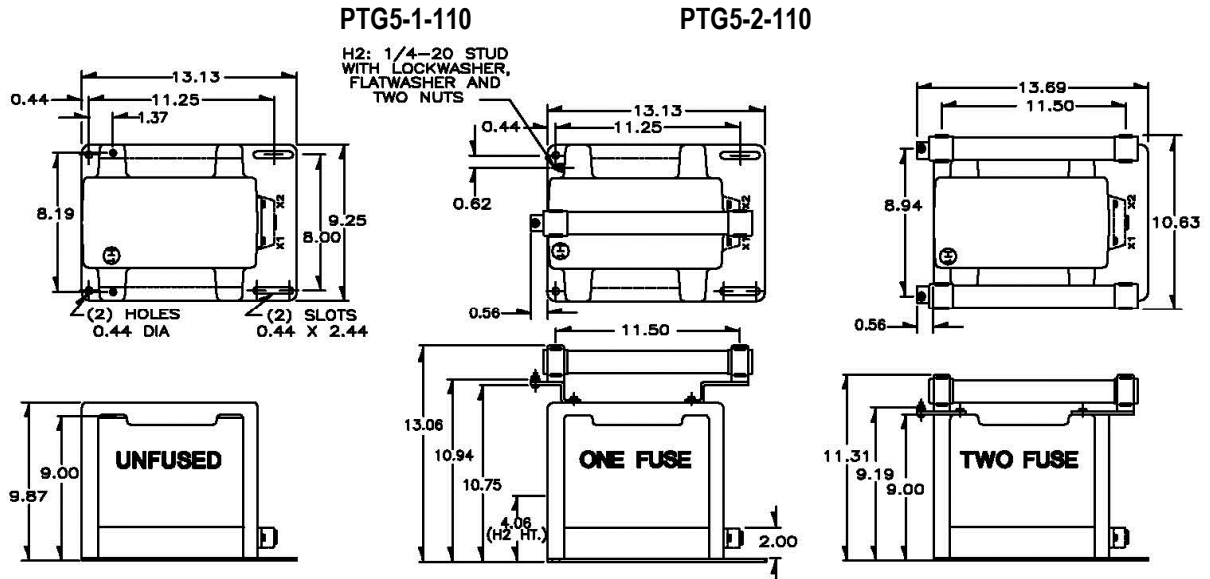

Recommended spacing is for guidance only. User needs to set appropriate values to assure performance for: high potential test; impulse test; high humidity; partial discharge, high altitude; and other considerations like configuration.

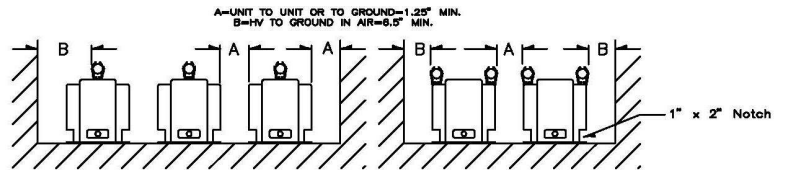

FUSE FOR MODEL PTG5 TRANSFORMER	RATING VOLTS	INTERRUPTING AMPERES (SYM)	SUGGESTED RATING * CONTINUOUS AMPERES	CAP DIA. INCHES	LENGTH INCHES	CLIP CENTERS INCHES
7200:120V	15.5kV	80,000	1.0E	1.63	13	11.50
8400:120V	15.5kV	80,000	1.0E	1.63	13	11.50
11000:110V	15.5kV	80,000	0.5E	1.63	13	11.50
12000:120V	15.5kV	80,000	0.5E	1.63	13	11.50
13200:120V	15.5kV	80,000	0.5E	1.63	13	11.50
14400:120V	15.5kV	80,000	0.5E	1.63	13	11.50

The circle diagram can be used to predict the performance of a transformer for various loads and power factors. A convenient scale of volt-amperes is shown on the unity power factor line (u.p.f.) and commences at the zero or no-load locus. To use the diagram, measure the known V.A. and scribe an arc about the "zero" locus of a length that contains the angle of the burden power factor. The point at which the arc terminates is the error locus in phase angle minutes and ratio correction factor.

